

APPROVED FOR FOOD AND DAIRY APPLICATIONS  
THE ONLY TRUE FOOD GRADE TAKEUP ON THE MARKET.

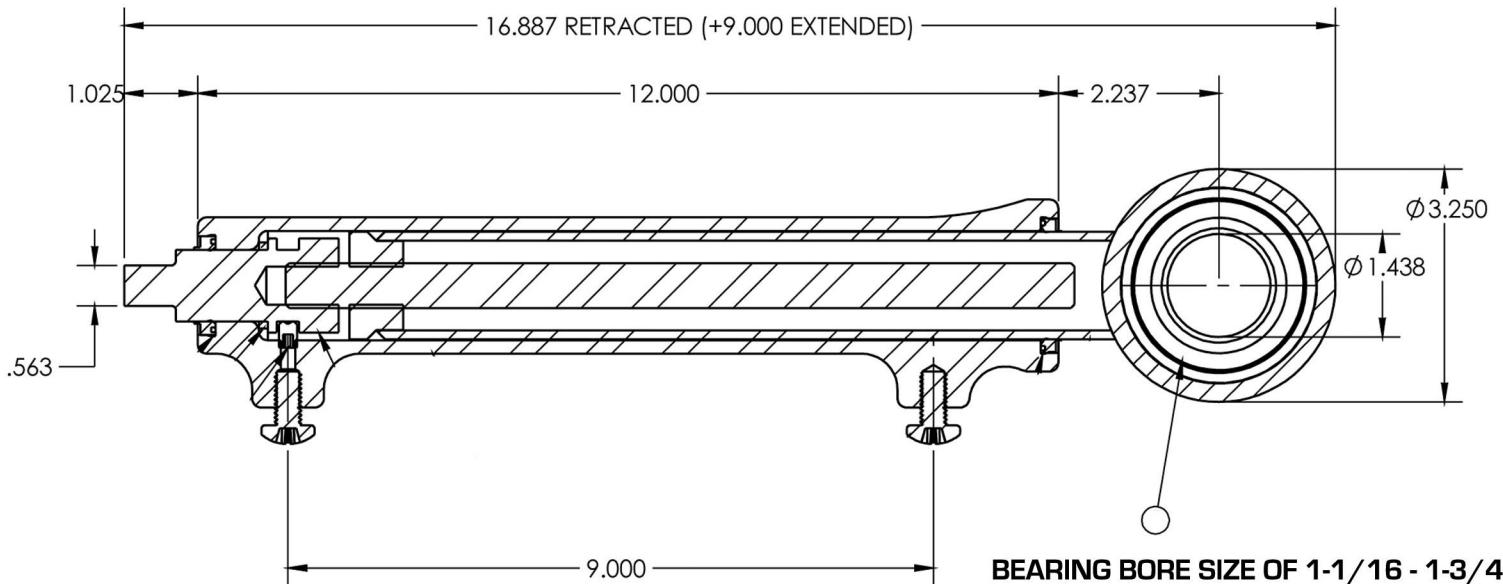

# **Telescop<sup>er</sup>** TAKE-UPS

- **STAINLESS STEEL ROUNDED BODY ELIMINATES STANDING SURFACE FOR FOOD AND DEBRIS**
- **UHMW SHIELDS PROTECT AND COVER THE BEARINGS PREVENTING FOOD AND DEBRIS BUILD UP IN THE COLLAR AND BEARING**
- **PLIABLE SEALS CLEAN THE SLIDER ASSEMBLY AND KEEP THE ADJUSTER ASSEMBLY FREE FROM FOOD AND LIQUID**
- **STAINLESS STEEL ADJUSTER IS FULLY ENCAPSULATED IN THE HOUSING**
- **INTEGRATED, SELF ALIGNING SPHERICAL BALL BEARING ENSURES A PERFECT CENTERLINE FOR OPTIMAL LOAD DISTRIBUTION**
- **SLEEK DESIGN ENSURES EASY AND THOROUGH CLEAN UP**



**BEARING BORE SIZE OF 1-1/16 - 1-3/4  
DESIGNED TO ACCOMMODATE  
3 - 9 INCHES OF TRAVEL**



\*OTHER BORE SIZES MAY BE AVAILABLE ON REQUEST

#### PRODUCT OFFERING

##### TAKEUPS

- TELESCOPER® BRAND TAKEUPS
- CUSTOM FABRICATED SPECIALTY TAKE-UPS

##### CONVEYOR ROLLERS

- 1-3/8" - 5" DIAMETER
- DRIVE GROOVES
- SPROCKETED - CDLR
- CARBON AND STAINLESS STEEL, ALUMINUM, ABS
- TAPERED ROLLERS & TURN PULLEYS
- AIRFORM® AND MACHINED STRAIGHT AND TRAP CROWN
- TIR AS LOW AS .001"
- 1" - 12" DIAMETER, 106" LENGTH

##### CONVEYOR PULLEYS

- AIRFORM® AND MACHINED STRAIGHT AND TRAP CROWN
- TIR AS LOW AS .001"
- 1" - 12" DIAMETER, 106" LENGTH

##### EXCLUSIVE TUFFCOTE® LAGGING

- HIGH QUALITY URETHANE AT RUBBER PRICES
- PULLEYS FOR GENERAL CONVEYING, AIRPORT BAGGAGE, UNITED PARCEL SERVICE, UNITED POSTAL SERVICE, PRINT AND WEB-FEED APPLICATIONS

##### CUSTOM FABRICATING

- CNC MACHINING - VERTICAL AND HORIZONTAL CENTERS

#### WELDING

- MIG
- AUTOMATIC CYLINDRICAL WELDING TO 10 INCH DIAMETER AND 1800 MM (72 IN) IN LENGTH
- TIG

#### PLASMA CUTTING

- ALUMINUM, ALLOY STEELS, AND STAINLESS STEEL

#### OTHER SERVICES

- PROPRIETARY AIRFORM® CNC METAL SPINNING
- TUBING CAPACITY (.250 WALL) MAXIMUM
- 2000 MM (80 INCHES) LENGTH
- UP TO 10 INCHES IN DIAMETER
- PROPRIETARY TUFFCOTE® URETHANE COATING OF ANY SUBSTRATE USING CNC CONTROLS
- MEDIA BLASTING
- CHROME PLATING

#### PROCESSES & CAPABILITIES

- CNC MACHINING
- TURNING CAPACITY UP TO 3000 MM (118 IN) IN LENGTH
- TURNING CAPACITY UP TO 15 INCHES IN DIAMETER
- TURNING CAPACITY INCORPORATES LIVE TOOLINGS FOR EXTRA PRECISION AND REDUCED SET UPS
- KEYS AND SPLINES PRODUCED ON LATHE
- MILLING CAPACITY UP TO 1800 MM (72 IN) IN LENGTH
- BAR FEED CAPACITY UP TO 3.50 INCHES IN DIAMETER
- HYDRAULIC STEADY REST CAPABILITY TO 10 INCHES IN DIAMETER
- CNC SAWING TO 20 INCH DIAMETER
- BROACHING - KEYWAYS

- ZINC PLATING
- HEAT TREATING
- POWDER COATINGS
- STRAIGHTENING
- PLASMA CUTTING
- GRINDING
- METAL FORMING
- MATERIAL OFFERINGS
- CARBON STEEL
- STAINLESS STEEL
- ALUMINUM
- PLASTICS
- STEEL ALLOY (4140, 1144, 8620, ETC)
- BRASS/COPPER ALLOYS
- TURNED, GROUND, AND POLISHED STOCK